

Coating heads from the RECO 800 and RECO 800 A series

Since 1958 RECO has been a well-known brand name in the field of coating and laminating machines and systems. The 800/800 A types make it possible to solve any task in the area of:

- solvent- and water-based compounds thermally drying and
- prepolymer coating solutions (environmentally friendly 100 % systems) that cure thermally or through radiation.

The features associated with RECO 800/800 A are unsurpassed on the world market:

- Modular structure, leading to high multifunctionality with over 60 coating processes gravure rollers, smooth rollers, comma bars, die/curtain coaters, Meyer bars, double-sided application and special forms (for more examples, see reverse side)
- Flexibility in width changes using sleeve technology
- Increased availability, including during changes in coating masses, through
 - Trolley technology (RECO 800 A) and
 - Gravure roller sleeve technology

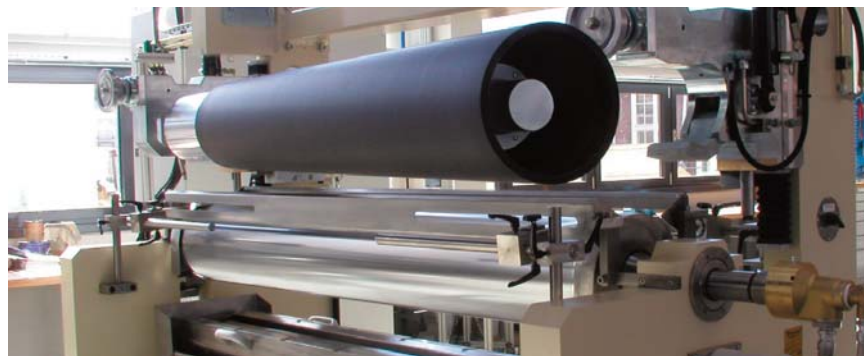

Fast, convenient sleeve change without tools

Two versions are available for the RECO series:

One version (the 800) has a fixed installed coating head, while the other version (the 800 A) uses a trolley system for quick changes of coating methods.

The exchangeable trolley system has many advantages. The aluminum construction ensures that it is easily handled.

The trolleys with gravure rollers do not require the doctor blade system to be reassembled when changing from parallel to reverse running.



The coating system has a fixed installation in the applicator, but can be changed



All application systems can be changed quickly because they are installed in a trolley system

Selection from the broad variety of coating processes

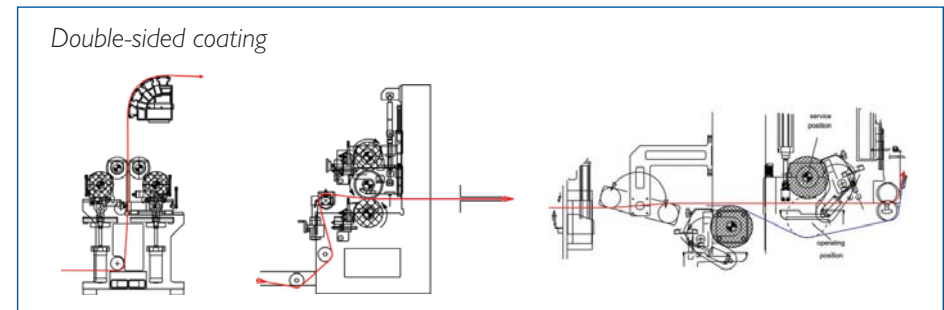
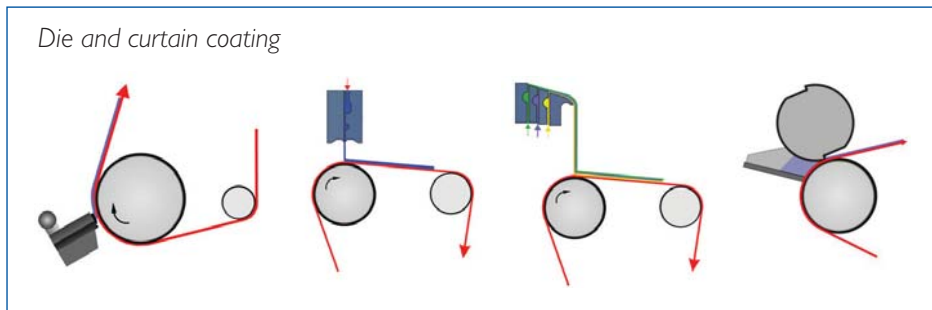
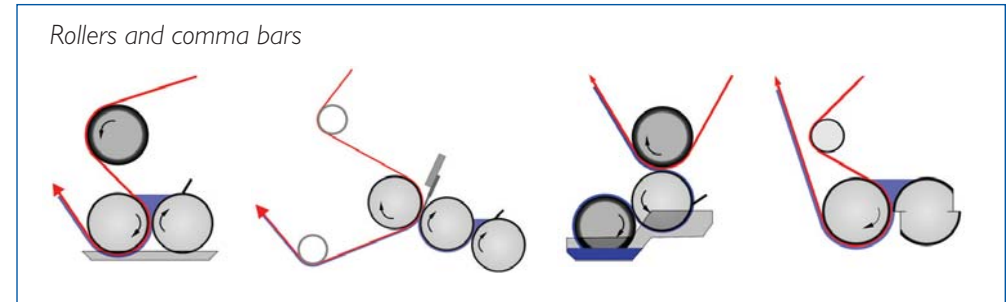
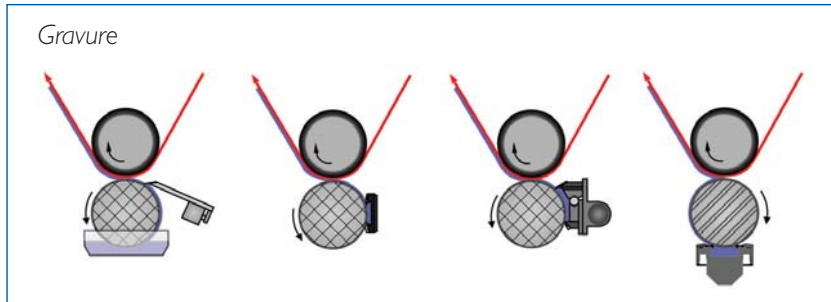

Technical data for the RECO 800/800 A

Working width	: 600 - 3,300 mm
Production speeds	: up to 1,600 m/min*
Roller diameter: application roller	: 250/300/400 mm
Sleeve pressure/application roller	: 190/250/300 mm

(* depending on application system)

